

DCL-23



Highlights

- Self-Inductance as low as 11nH
- ESR as low as 0.5 mΩ
- Low profile
- High thermal conductivity
- Life expectancy as high as 100 Khrs
- Integrated mounting flanges
- Flame retardant UL94 - V0, ROHS compliant

Construction

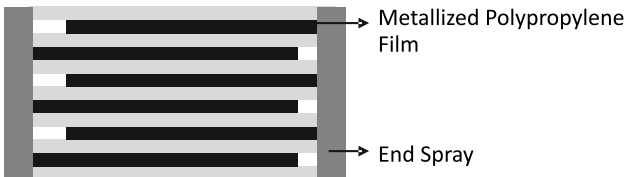

Applications

- DC filtering
- Wind power inverters
- Solar power inverters
- Induction heaters
- Electric vehicle inverters
- Motor drives

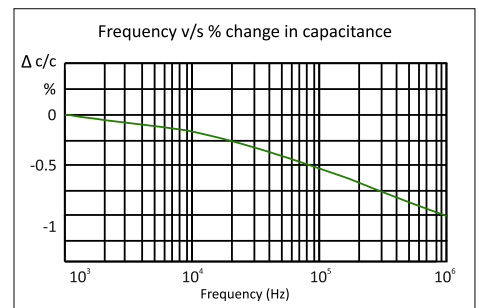
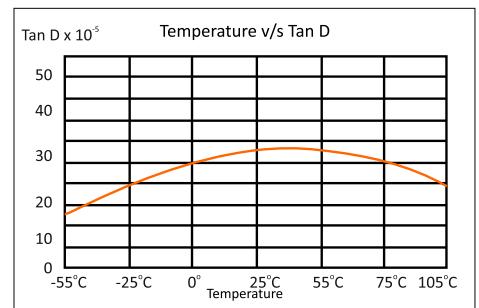
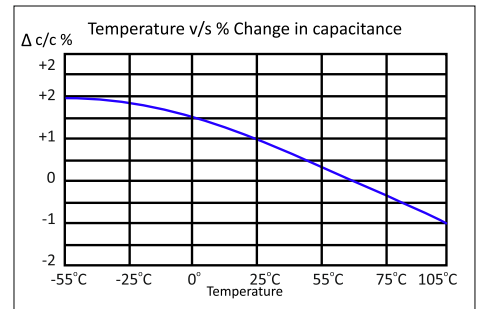
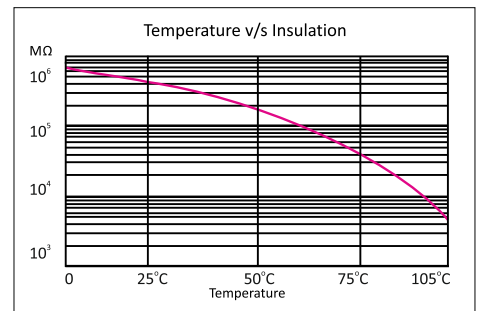
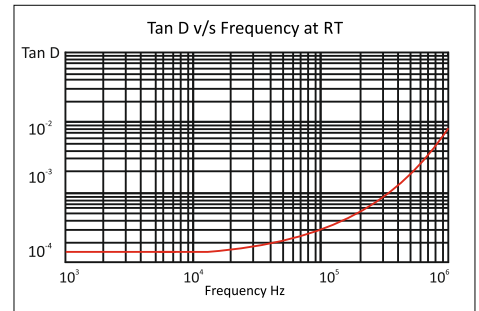

DCL-23

Technical Specifications

Physical Characteristics

▪ Electrode material	Metallised polypropylene film
▪ Winding construction	Polypropylene film, metallised polypropylene film
▪ Enclosure	Preformed UL 94-V0 plastic case with thermosetting resin-fill
▪ Terminals	Nickel plated brass

Electrical Characteristics

▪ Capacitance range	12 μ F to 265 μ F
▪ Capacity tolerance	\pm 5%(J), \pm 10%(K)
▪ Rated voltage VDC	700, 800, 900, 1000, 1200, 1400, 1600, 1800
▪ Test voltage between terminals	1.3 x rated voltage VDC for 60 seconds (not to be repeated)
▪ Test voltage terminal to case	3KVAC at 50Hz for 60 seconds
▪ Dissipation factor (Tan d)	\leq 0.0015 at 100Hz and 25 $^{\circ}$ C
▪ Temperature range	-40 $^{\circ}$ C to +105 $^{\circ}$ C
▪ Insulation resistance $M\Omega \times \mu$ F	\geq 5,000 S at 25 $^{\circ}$ C (S = $M\Omega \times \mu$ F)
▪ Reference Standard	IEC 61071 and IEC 60068

Marking on Capacitors

Each capacitor will have the following information printed on it, sequentially:

- The Company's symbol  followed by the words ALCON
- The capacitor grade viz DCL-23
- The capacitance value MFD
- The rated voltage VDC
- The max current Arms
- Capacity tolerance and manufacturing code
- Part number on non-standard capacitors

DCL-23

Standard Capacitors Values

Rated voltage VDC	Nominal Capacitance MFD at 1 KHz	Case size $\phi \times Lmm$	Case Code	Typical ESR m Ω at Fr* KHz	Fr** KHz	Rise in core temperature per watt dissipated $^{\circ}C$	Ripple current rating Irms at 10 KHz to 100KHz					Ordering Code
							25 $^{\circ}C$	45 $^{\circ}C$	65 $^{\circ}C$	85 $^{\circ}C$	105 $^{\circ}C$	
700	85	85 x 40	Y1	0.65	156	14.2	91	79	66	46	11	SD000850700AQ0Y1___K01
	100	85 x 51	Y2	0.75	105	12.3	96	83	69	49	12	SD001000700AQ0Y2___K01
	142	85 x 51	Y2	0.75	105	12.3	96	83	69	49	12	SD001420700AQ0Y2___K01
	205	85 x 64	Y3	0.95	71	10.8	87	75	63	44	10	SD002050700AQ0Y3___K01
	265	85 x 79	Y4	1.65	61	8.9	77	67	55	39	9	SD002650700AQ0Y4___K01
800	70	85 x 40	Y1	0.56	168	14.2	86	74	61	42	9	SD000700800AQ0Y1___K01
	88	85 x 40	Y1	0.65	156	14.2	91	79	66	46	11	SD000880800AQ0Y1___K01
	140	85 x 51	Y2	0.75	105	12.3	96	83	69	49	12	SD001400800AQ0Y2___K01
	200	85 x 64	Y3	0.95	71	10.8	87	75	63	44	10	SD002000800AQ0Y3___K01
	260	85 x 79	Y4	1.65	61	8.9	77	67	55	39	9	SD002600800AQ0Y4___K01
900	65	85 x 40	Y1	0.50	68	14.2	84	92	59	40	8	SD000650900AQ0Y1___K01
	100	85 x 51	Y2	0.78	98	12.3	93	81	71	51	12	SD001000900AQ0Y2___K01
	150	85 x 64	Y3	0.97	73	10.8	85	76	64	45	13	SD001500900AQ0Y3___K01
	200	85 x 79	Y4	1.70	69	8.9	75	65	53	37	8	SD002000900AQ0Y4___K01
1000	47	85 x 40	Y1	0.80	176	14.2	85	73	62	38	10	SD000471000AQ0Y1___K01
	52	85 x 40	Y1	1.00	182	14.2	87	75	63	44	10	SD000521000AQ0Y1___K01
	88	85 x 51	Y2	0.80	136	12.3	89	77	64	45	11	SD000881000AQ0Y2___K01
	120	85 x 64	Y3	1.18	91	10.8	78	68	56	40	9	SD001201000AQ0Y3___K01
	170	85 x 79	Y4	2.21	75	8.9	69	60	50	35	8	SD001701000AQ0Y4___K01
1200	38	85 x 40	Y1	1.05	254	14.2	72	62	52	37	9	SD000381200AQ0Y1___K01
	63	85 x 51	Y2	1.19	179	12.3	74	64	53	38	9	SD000631200AQ0Y2___K01
	88	85 x 64	Y3	1.46	116	10.8	69	60	50	35	8	SD000881200AQ0Y3___K01
	118	85 x 79	Y4	2.80	96	8.9	57	49	41	29	7	SD001181200AQ0Y4___K01
1400	20	85 x 40	Y1	1.28	294	14.2	63	55	45	32	8	SD000201400AQ0Y1___K01
	34	85 x 51	Y2	1.47	218	12.3	64	55	46	33	8	SD000341400AQ0Y2___K01
	48	85 x 64	Y3	1.87	143	10.8	61	53	44	31	7	SD000481400AQ0Y3___K01
	64	85 x 79	Y4	3.81	124	8.9	52	45	37	27	6	SD000641400AQ0Y4___K01
1600	18	85 x 40	Y1	1.48	352	14.2	62	54	45	32	7	SD000181600AQ0Y1___K01
	30	85 x 51	Y2	1.71	260	12.3	62	54	45	32	7	SD000301600AQ0Y2___K01
	42	85 x 64	Y3	2.18	171	10.8	59	51	42	30	7	SD000421600AQ0Y3___K01
	55	85 x 79	Y4	4.56	151	8.9	48	42	35	24	6	SD000551600AQ0Y4___K01
1800	12	85 x 40	Y1	1.69	460	14.2	57	49	41	29	7	SD000121800AQ0Y1___K01
	21	85 x 51	Y2	1.86	236	12.3	58	50	42	30	7	SD000211800AQ0Y2___K01
	30	85 x 64	Y3	2.81	226	10.8	50	43	36	26	6	SD000301800AQ0Y3___K01
	40	85 x 79	Y4	5.63	185	8.9	43	37	31	22	5	SD000401800AQ0Y4___K01

Custom designed capacitors are available on request

** Fr =Typical resonant frequency (Tol.±30%)

DCL-23

Capacitor Drawing and Terminal Styles

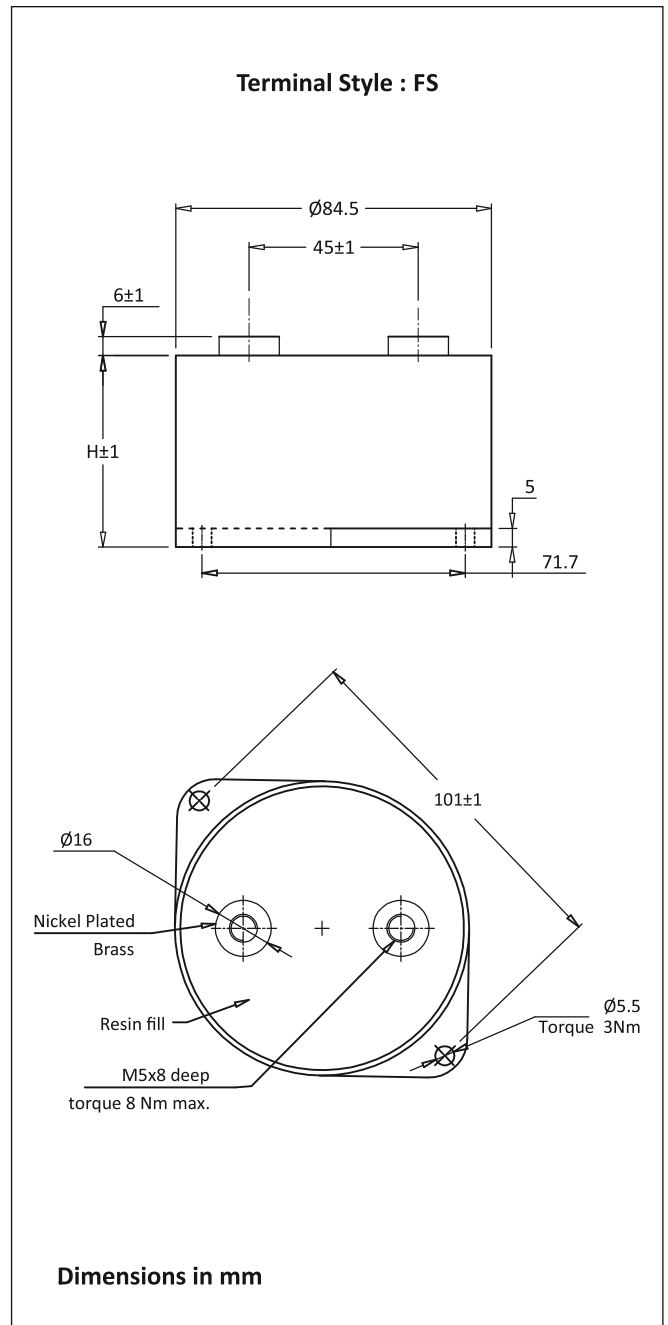
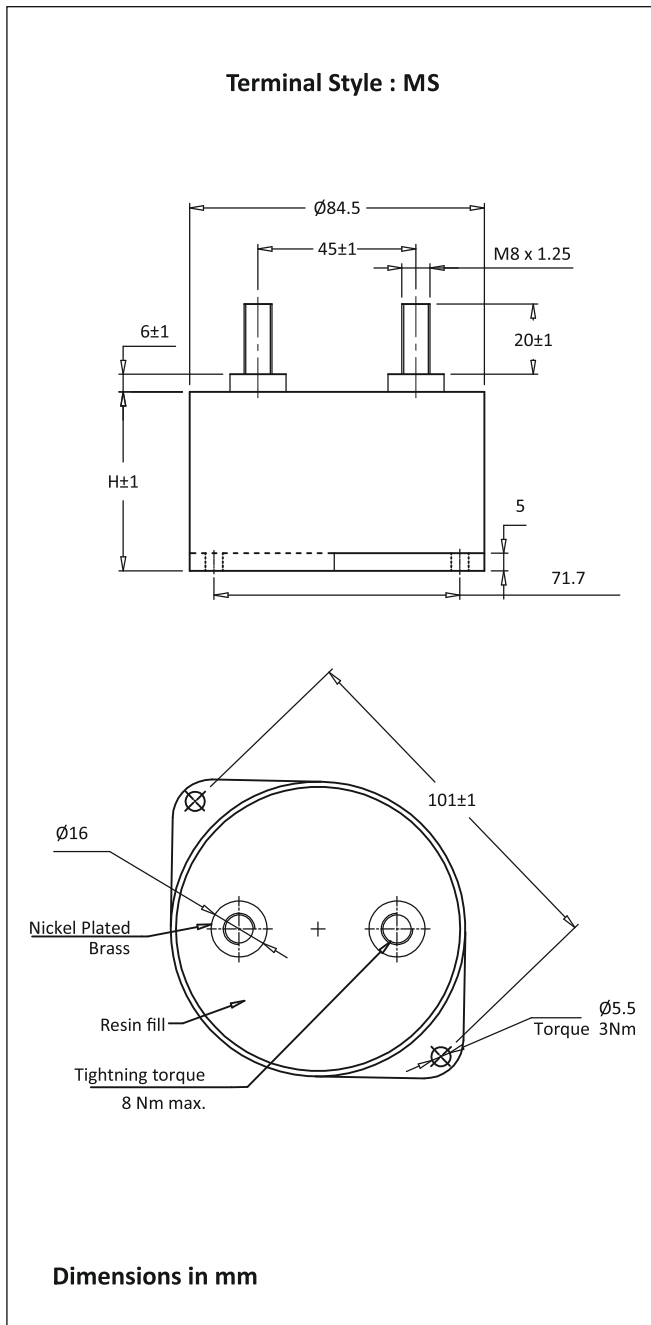

DCL-23

Life Expectancy

Steps to calculate Hotspot Temperature

- 1 Locate the capacitor and the ESR from the electrical specifications
- 2 Dissipated heat = ($I_{rms}^2 \times ESR$)
- 3 Get the value from table 1 for Rth (°C/watt)
- 4 Calculate internal temperature rise = ($I_{rms}^2 \times ESR$) x Rth (°C/watt)
- 5 Hotspot temperature of capacitor = T Ambient + ($I_{rms}^2 \times ESR$) x Rth (°C/watt)
- 6 From the graph given below expected life can be obtained
- 7 Ensure that the voltage and current specification are not exceeded

Can size D x H	Rth °C/Watt
85 x 40	14.2°C
85 x 51	12.3°C
85 x 64	10.8°C
85 x 79	8.9°C

Example: If 88 MFD/800 VDC is being used at 40 Arms in a 40°C Ambient; then ESR from the table (on page 4) = 0.00065Ω and the case size is ø85 x 40mm

The dissipated wattage = 40 x 40 x 0.00065Ω = 1.04 watts

Temperature rise = 1.04 x 14.2°C/Watt = 14.76°C

The hotspot core temperature inside the capacitor = 40°C (Ambient) + 14.76 (Rise) = **54.76 say 55°C**

From the graph below: If the capacitor is being used at 75% of Vrdc then the expected life will be approx 480,000 hours

